

MORE FROM WOOD.

E EGGER

Compact Laminates

The elegant solution even for
increased stress

Decorative Collection 24+

“Thanks to their construction and product properties, EGGER compact laminates offer a wide range of solutions even for demanding applications in furniture and interior design.”

*Karel Scharnagl
(Application Engineer Compact Laminates)*

Get there faster



On the topic
in this PDF



On the topic on the
EGGER page



Enlarge
picture view



Back to
table of contents



Interactive table of contents

- » 1. Compact Laminates
- » 2. EGGER Compact Laminates range
- » 3. Decor overview
- » 4. Overview of textures
- » 5. Application examples
- » 6. Technical realisation
 - 6.1 Wall cladding
 - 6.2 Shower splashback and sanitary partition
 - 6.3 Tabletops
 - 6.4 Compact Laminate worktops
 - 6.5 Furniture doors
- » 7. Processing instructions
 - 7.1 Use of compact laminates
 - 7.2 Processing
 - 7.3 Cleaning and use recommendation
 - 7.4 Environment and health
- » Services of the Decorative Collection 24+

1. Compact Laminates

are decorative multi-layer compact laminates in accordance with EN 438-4 (black core), EN 438-8 (pearlescent decors) and EN 438-9 (coloured core) with a thickness of 2 mm or greater.

Their durability and moisture resistance make them the ideal material for interior applications with increased stress and requiring special attention to hygiene and cleanliness. They are also very often used in humid conditions such as bathrooms, sanitary rooms and changing rooms.

Elegant, hygienic, robust

 Wear-resistant

 Lightfast when used indoors

 Resistant to everyday cleaning products and chemicals

 Impact- and scratch resistant

 Food-safe

 Antibacterial surface property according to ISO 22196 (= JIS Z 2801)

 Hygienic

 Resistant to stains





Versatile in processing

The homogeneous core of the compact laminate is ideal for precise processing. For example, for elements with customised milling with a 3D effect. The board can be milled, grooved and drilled according to your specifications, either on the surface or in the core. Milling is possible anywhere on the board.

Simple and high-quality

Slim and linear elements create a very design-orientated interior. The compact laminate impresses with its elegant design, combined with stability and robustness.

It is an attractive alternative to the use of metal in interior design. Uni colours and wood and material reproductions open up a wide range of design options. This variety of designs makes it the highlight of your planning.



Universal and durable

The compact laminate is great for humid conditions or applications with increased stress such as tables, work surfaces, wall cladding, changing rooms and partition walls. With this product, you can create a modern, durable design even for functional rooms. Its diverse processing options offer room for creative design solutions.



Furniture as if cast from a single mould

The compact laminates with a coloured core offer you three attractive, timeless decors that make furniture look as if it has been cast from a single mould. Whether mitred or bevelled, the coloured core means that butt joints and joints remain almost invisible. The narrow sides of the boards become a design element.



Perfectly combined

Most of the decors available as compact laminates are also available as laminated chipboard, lightweight boards or MDF, laminates and edging. An offer which brings together technical, aesthetic, and economic requirements.

» Details on the product availability of EDC24+ decors can be found in the [digital availability guide](#)





2. EGGER Compact Laminates range

Compact laminates are the established solution for durable interior design with increased stress. They have an attractive design and excellent product properties.

In combination with the large variety of decors and the wide range of products, they are the ideal material for your interior applications.

YOUR ADVANTAGES

- Homogeneous material for precise machining
- No edging required
- Large format with low cutting waste
- Comprehensive decor variety
- Extended stock programme available at short notice
- Available in decor match with other EGGER products
- Tapped holes and all types of surface milling possible
- Antibacterial surface property according to ISO 22196 (= JIS Z 2801)
- Low emissions:
"TÜV PROFICERT-product Interior"

Compact laminates have a multilayer structure. The papers used for the product are first impregnated with resin and then pressed together under heat and high pressure. The material types are differentiated within EN 438 using a classification system with three letters.

You can obtain the following material types from EGGER:

EN 438-4 Compact Laminates

- CGS - Compact General-purpose Standard
- CGF - Compact General-purpose Flame retardant

EN 438-8 Design Laminates

- ACS - Pearlescent laminate Compact Standard grade
- ACF - Pearlescent laminate Compact Flame retardant

EN 438-9 Alternative Core Laminates

- BCS - Coloured core laminate Compact Standard grade

Product variants

Type	Thicknesses (mm)	Sizes (mm)	Fire class
Compact Laminates Black Core	3/4/5/6/8/10/12/13	5,600/2,790 × 2,060	Fire class D-s2, d0 type CGS
Compact Laminates Coloured Core	6/8/10/13	5,600/2,790 × 2,060	-
Compact Laminates Flammex Black Core	6/8/10	5,600/2,790 × 2,060	Fire class B-s2, d0 / B-s1, d0*
Compact Laminate Worktops Black Core	12	4,100 × 650 / 920 / 1,300	Fire class D-s2, d0 types CGS
Compact Laminate Worktops Coloured Core	12	4,100 × 650 / 920 / 1,300	-

* B-s2,d0 (according to EN438-7 > standardised construction with 30 mm wooden substructure) or B-s1,d0 (individual classification > substructure made of Flammex compact laminate strips 6 mm)





Compact Laminates Black Core

With their homogeneous structure, durability and moisture resistance, compact laminates black core offer a design-oriented solution for interior applications with increased stress in the commercial sector. They are referred to in standards as type CGS or ACS (pearlescent version).

Application areas: Wall cladding, cubicle and partition wall construction, work surfaces in offices and kitchens, hospital interior and furniture construction.



Compact Laminates Coloured Core

They set special accents thanks to their coloured core. The solid-coloured look is perfectly accentuated with mitred elements. Joints and butt joints are almost invisible. Their structure is identical to that of the compact laminates with a black core. They are referred to in standards as type BCS.

Application areas: Wall cladding, cubicle and partition wall construction, work surfaces in offices and kitchens, hospital interior and furniture construction.



Compact Laminates Flammex®

They are similar in appearance to the compact laminate black core. However, they are characterised by a significantly improved fire resistance and are classified as B-s2, d0 in accordance with EN 13501-1. Compact laminates Flammex have low flammability, smoulder moderately, and do not drip. With reduced ventilation and low-flammability or non-flammable substructure, the Flammex compact laminates may even be classified and used as B-s1, d0. They are referred to in standards as CGF or ACF (pearlescent version).

Application areas: Wall, ceiling cladding and furniture construction in buildings or areas with increased fire behaviour requirements

Product structure





Compact Laminate Worktops Black Core

The 12 mm thin compact laminate worktop is designed with bevelled milling on the top and bottom of the long edges. The black core colour underlines the modern design of these worktops in the edging area.

Application areas: Worktops, office desks, washbasins



Compact Laminate Worktops Coloured Core

The 12 mm thin compact laminate worktops are made with bevel milling on the top and bottom of the long edges. The core colours white, light grey and dark grey are perfectly matched to the available decors and underline the modern design of these worktops in the edging area.

Application areas: Worktops, office desks, washbasins

Information on our sustainability indicators (EcoFacts) can be found on the product detail pages – see links  on pages 10 and 12 of this brochure.

 Please find detailed information on the product detail pages at to.egger.link/compactlaminate. You will find technical data sheets, processing instructions, cleaning recommendations and certificates in the download area of the respective product detail page.

Assembly accessories Compact Laminate Worktops

Connectors for 12 mm worktops



Sealing for corner joints



Splashbacks



Product structure

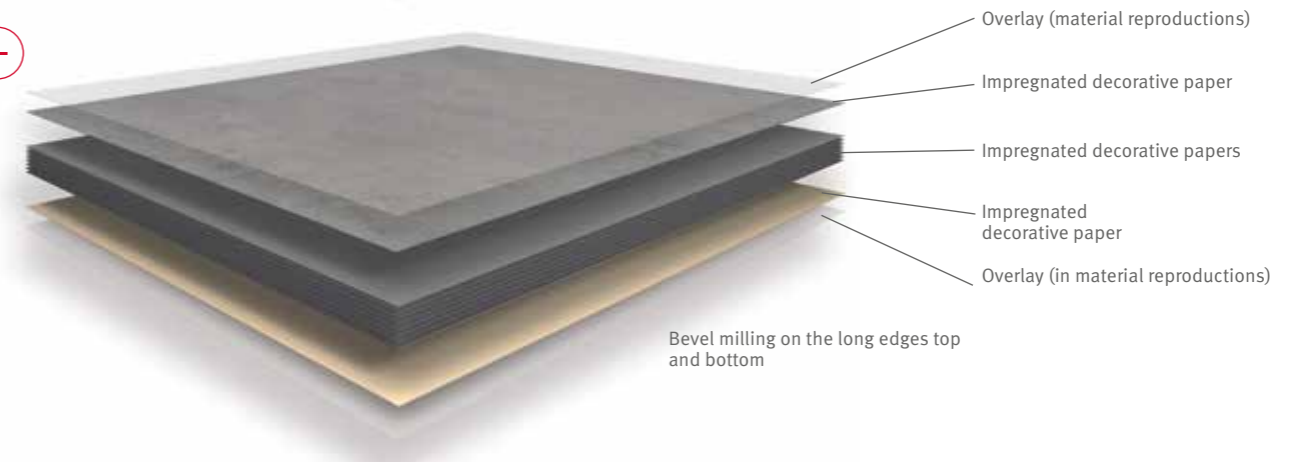
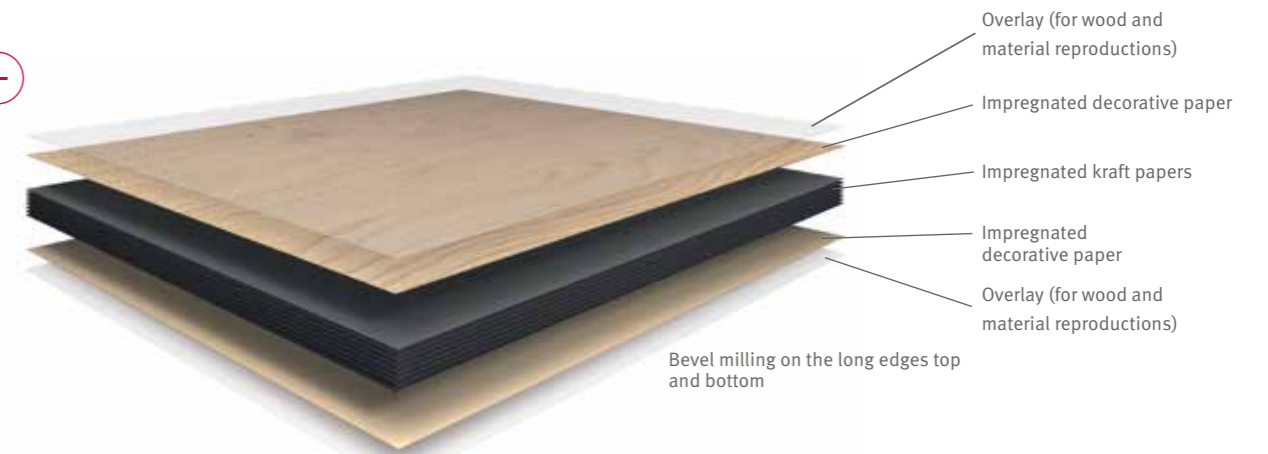









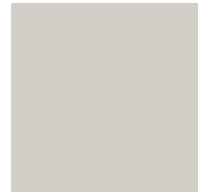

Compact Laminate Worktops

The 12 mm thick boards are bevelled on the top and bottom of the long edges. This saves time and costs during packing. They are available in the core colours black, white, light grey or dark grey to match the respective decor.



[» To sample orders](#)

Available decors

					
W1101* ST76 Solid Alpine White	U7081* ST76 Solid Light Grey	U999 ST76 Black	H1318 ST10 Natural Wild Oak	H1330 ST10 Vintage Santa Fe Oak	F1861* ST9 Solid Light Grey Chicago Concrete
					
F206 ST9 Black Pietra Grigia	F221 ST87 Cream Tessina Ceramic	F244 ST76 Anthracite Candela Marble	F247 ST76 Anthracite Mountain Basalt	F311 ST87 Ceramic Anthracite	* Coloured core



Slim design

Thin worktops are enjoying increasing popularity thanks to their minimalist and straightforward look. Compact laminate worktops offer an attractive solution ready to be installed.

Combinable and resilient

A counter adjacent to the worktop or a bar add liveliness to the kitchen. Here you can prepare food, chat, work and study – all at the same time if necessary. The counter area in the kitchen is often set off from the actual work surface by a different material thickness or a different material. This combination of contrasting looks adds impact to the design.



YOUR ADVANTAGES

- Temperature- and moisture-resistant
- Time and cost savings thanks to pre-bevelled long edges
- Suitable for undermount sinks and built-in hobs
- **New** 1,300 mm width for kitchen islands without joints
- Resistant to many cleaning agents and chemicals

» With our worktop configurator, you can very easily, quickly and individually create worktops, splashbacks and flanks. Click [here](#) for more details

» Details on the product availability of the compact laminate worktop decors can be found [here](#)

All our shown and mentioned decors are reproductions.



3. Decor overview

All the decors shown below are available as compact laminates, each laminated on both sides with the same decor. Additional products are available for almost all decors for a uniform room design.

Details on the product availability of EDC24+ decors can be found in the [digital availability guide](#)

Compact Laminates Black Core





H1710 ST10
Sand Kentucky Chestnut



H1732 ST9
Sand Birch



H1910 ST9
Willow Beech



H2033 ST10
Dark Hunton Oak



H3012 ST22
Coco Bolo



H3133 ST9
Truffle Brown Davos Oak



H3146 ST22
Beige Grey Lorenzo Oak



H3156 ST9
Grey Corbridge Oak



H3157 ST9
Vicenza Oak



H3158 ST22
Grey Vicenza Oak



H3170 ST9
Natural Kendal Oak



H3171 ST9
Oiled Kendal Oak



H3303 ST10
Natural Hamilton Oak



H3331 ST10
Natural Nebraska Oak



H3332 ST10
Grey Nebraska Oak



H3368 ST9
Natural Lancaster Oak



H3395 ST9
Natural Corbridge Oak



H3398 ST9
Cognac Kendal Oak



H3430 ST22
White Aland Pine



H3433 ST22
Polar Aland Pine



H3450 ST22
White Fleetwood



H3700 ST10
Natural Pacific Walnut



H3710 ST9
Natural Carini Walnut



H3730 ST10
Natural Hickory



H3734 ST9
Natural Dijon Walnut



F186 ST9
Light Grey Chicago Concrete



F187 ST9
Dark Grey Chicago Concrete



F226 ST87
Sand Beige Titanite



F228 ST87
Anthracite Titanite



F237 ST76
Cupria Slate



F243 ST76
Light Grey Candela Marble



F244 ST76
Anthracite Candela Marble



F302 ST87
Ferro Bronze

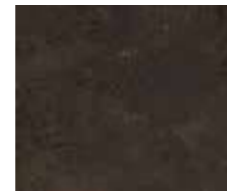

F311 ST87
Ceramic Anthracite

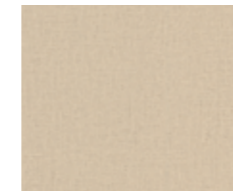

F416 ST10
Beige Textile



F417 ST10
Grey Textile



F422 ST10
White Linen



F424 ST10
Brown Linen



F433 ST10
Anthracite Linen



F634 ST76
Grey Canvas

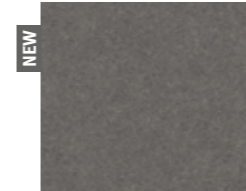

F635 ST76
Anthracite Canvas



F637 ST10
White Chromix

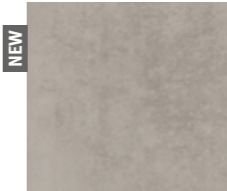

F638 ST10
Chromix Silver

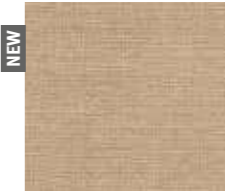

F685 ST10
Acapulco



F800 ST9
Crystal Marble



F812 ST9
White Levanto Marble

Compact Laminates Coloured Core



W1101* ST9
Solid Alpine White

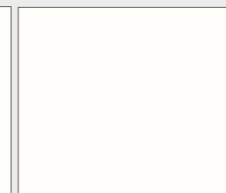

W1101* ST76
Solid Alpine White



U7081* ST9
Solid Light Grey

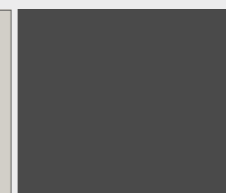

U9631* ST9
Solid Diamond Grey

Compact Laminate Worktops

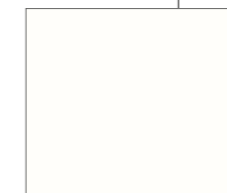

W1101* ST76
Solid Alpine White



U7081* ST76
Solid Light Grey



U999 ST76
Black



H1318 ST10
Natural Wild Oak



H1330 ST10
Vintage Santa Fe Oak



F1861* ST9
Solid Light Grey Chicago Concrete



F206 ST9
Black Pietra Grigia

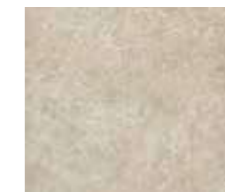

F221 ST87
Cream Tessina Ceramic



F244 ST76
Anthracite Candela Marble

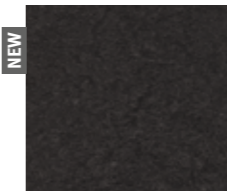

F247 ST76
Anthracite Mountain Basalt

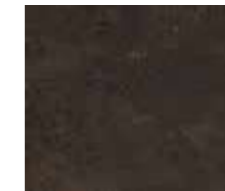

F311 ST87
Ceramic Anthracite

* Coloured core

4. Overview of textures

In the era of advancing digitalisation, the sense of touch has become increasingly important. That is why EGGER pays particular attention to textures and surfaces. The harmonious feel which complements the decor image rounds off the overall design. With expressiveness, character, depth and naturalness, you can complete outstanding projects to the utter satisfaction of your customers.



ST7
Smoothtouch Fine Pearl
The ST7 Smoothtouch Fine Pearl surface texture is a neutral, usable and rather matt surface



ST9
Smoothtouch Matt
The ST9 Smoothtouch Matt surface texture provides a neutral, velvety-matt feel on uni, wood and material decors.



ST10
Deepskin Rough
ST10 Deepskin Rough gives mainly natural and original woodgrain decors an authentically rough feel, which is rather reserved thanks to its continuous matt look.

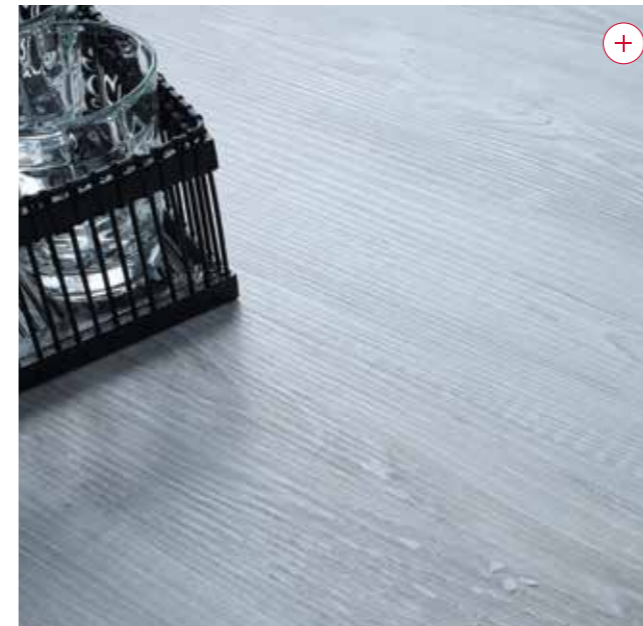

ST22
Deepskin Linear
The feel and matt-gloss effect of ST22 Deepskin Linear give rather linear woodgrain decors a noticeably deep character and a natural, brushed look, as is often seen in conifers.



ST37
Feelwood Rift
ST37 Feelwood Rift is synchronised with the Halifax Oak decor series. It makes the crack in the decor image particularly noticeable through a deep haptic. This gives Halifax Oak an incredibly real solid wood character in look and feel.



ST76
Mineral Rough Matt
The ST76 Mineral Rough Matt is based on a mottled and slightly rough natural stone surface. It gives a wide variety of stone reproductions, from marble to slate, a visually neutral surface with an authentically rough feel that also conveys a certain robustness to the customer.

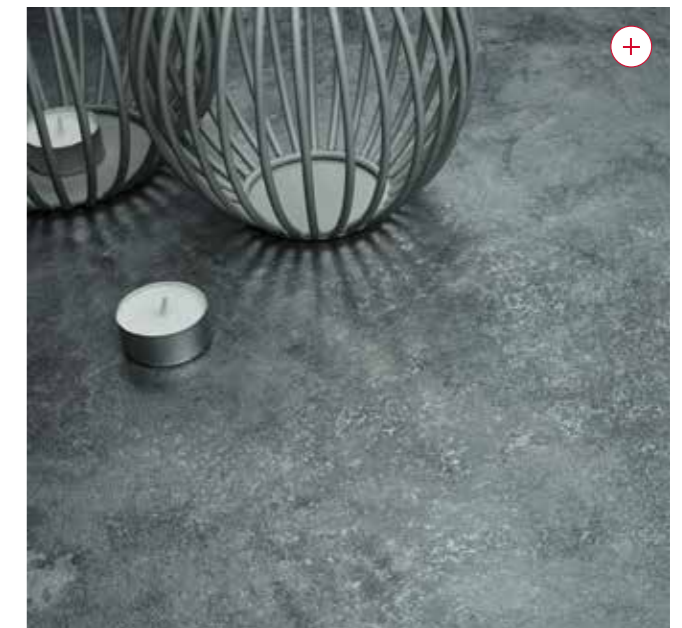

ST87
Mineral Ceramic
With strong matt-gloss effects, ST87 Mineral Ceramic replicates the striking look and feel of a ceramic tile, making it the perfect surface texture for worktops.

5. Application examples

Bathrooms

Particularly in humid conditions such as bathrooms, the compact laminate shows off its aesthetic and technical strengths. The monolithic impression created by the matching solid-coloured core in combination with the moisture resistance leaves plenty of scope for your ideas, both in terms of design and construction.



Cubicle construction, lockers and changing rooms

Hygiene plays a major role in public bathrooms. The moisture-resistant compact laminate is easy to clean and also has antibacterial surface properties.

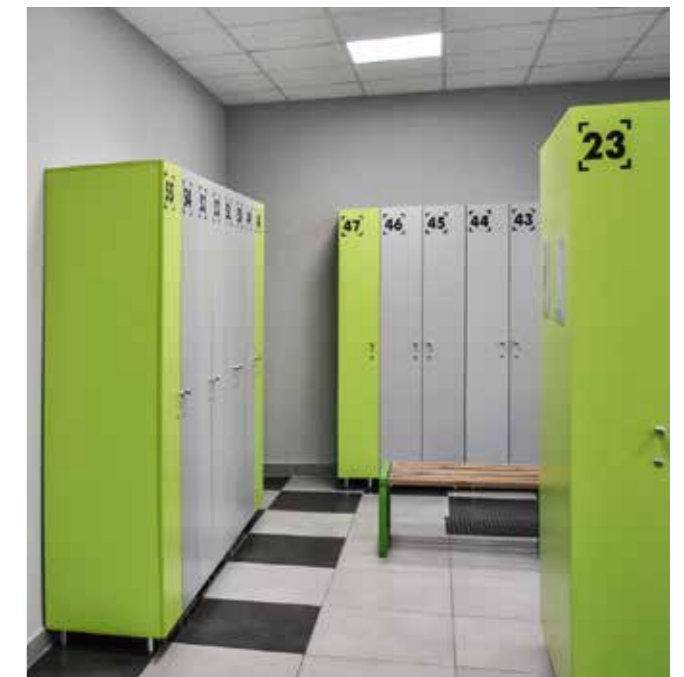



© Fotografische Werkstatt Katharina Jaeger

Clean rooms and laboratories

Compact laminates are also very suitable for furnishing various laboratories and clean rooms. They are hygienic, resistant to many chemicals and have an antibacterial surface property. Their resistance to moisture as well as abrasion, impact and scratches is also highly valued in these areas.



© Fotografische Werkstatt Katharina Jaeger

Healthcare

Cleanliness and hygiene play an important role in hospitals, doctors' surgeries and care facilities. Used as wall cladding or classically in furniture construction, the compact laminate, with its closed surface, offers decisive advantages at the transition to the edge or at the edge itself.

» For disinfectants tested by us, please refer to the technical data sheet [Resistance of EGGER surfaces to disinfectants](#)





Wall cladding, wall and impact protection

Particularly in public areas, wall cladding must be safe and durable. Here, the compact laminate scores with its stability, clear design and its resistance to abrasion, impact and scratches.

© Fotografische Werkstatt Katharina Jaeger

Stairs construction

Cool elegance, high functionality. The look of the flanks is reminiscent of steel staircases. Combined with the warm wood colour of the stairs, they merge into a modern, timeless unit. The surfaces of the compact laminates are light-resistant. The stable material is also impact-resistant and has high tensile and bending strength.



Photos: © Finger Treppen





© andreaswimmer.com

Furniture construction

The compact laminate impresses with more than just its attractive design. Thanks to its excellent physical characteristics, it offers a wide range of applications in furniture and interior design. For individual designs, milling and drilling is possible anywhere on the board. With a coloured core, even the narrow side of the furniture becomes an eye-catcher.



© Fotografische Werkstatt Katharina Jaeger



© Fotografische Werkstatt Katharina Jaeger



Kitchens

Upgrading through simplification – that's what design has to be able to do nowadays.

In the kitchen, this trend is often realised holistically with simple, slim lines. The compact laminate offers an attractive and high-quality solution for table and work surfaces.



© Fotografische Werkstatt Katharina Jaeger

6. Technical realisation

6.1 Wall cladding

Thanks to their robustness and suitability for everyday use, compact laminates are particularly well suited for use as interior wall cladding. We recommend a minimum board thickness of 8 mm for such applications. The substructure should be completely dry prior to applying the cladding. Always ensure sufficient rear ventilation or acclimatisation of the boards. The material should not be exposed to trapped moisture. All parts to be joined together must follow the same production direction.

6.1.1 Substructure and rear ventilation

Compact laminates must be attached to a stable, corrosion-resistant and force-fit substructure that securely supports the weight of the wall cladding and ensures rear ventilation. In dry construction applications, the attachment of the substructure and the compact laminate must be anchored to the stud framing. The selection of the fasteners has to be tailored to the substructure and the weight of the wall cladding. Different ambient conditions in front of and behind the elements can lead to warpage. It is therefore

essential that compact laminate wall cladding always makes provision for adequate rear ventilation, which allows temperature and humidity to equalise. The installation should be vented into the room.

If there is no rear ventilation or a rear ventilation gap smaller than 2 cm, absorbent mineral substrates such as walls or the plaster must be pre-treated with waterproof, elastic barriers. Possible damp proofing can be found [» in section 6.1.3 Assembly details](#)

These barriers are generally painted on and prevent the penetration of water into the masonry, which is essential for use in humid conditions. You can find more information about the use of compact laminates in humid conditions [» in section 6.2](#)

Vertical battens generally permit air circulation. Where substructures are arranged horizontally, an appropriate construction must ensure that adequate rear ventilation is provided. The substructure should be vertically plumb to allow stress-free mounting of the entire board surface. Suitable substructures include vertical strips of wood, aluminium or compact laminate.

The maximum spacing of the battens and/or substructure depends on the chosen compact laminate thickness. It is important to ensure that air inlet and outlet areas remain unobstructed so that air circulation is not impeded. Also ensure that the moisture of the surface to be panelled does not differ significantly from the moisture of the finished wall panel.

The following are differentiated:

- visible mechanical mount
- invisible mechanical mount
- invisible glued mount

Possible EPDM tape

- MBE EPDM joint tape
- Innotec EPDM joint tape

6.1.2 Mount options

Visible mechanical mount

Mounting is done via screws or rivets on the substructure. A sufficient dilation gap and the right positioning of sliding and fixed points must be taken into account. An EPDM* tape must be used for decoupling when using wood as substructure (see Fig. 1). The fasteners are available with head varnish to match the decors. The rivets must be fitted with an attachment that allows approx. 0.2 mm play in the rivet at the sliding points.

* EPDM stands for ethylene propylene diene monomer and is a synthetic rubber. EPDM is very resistant to UV, ozone and other atmospheric influences.

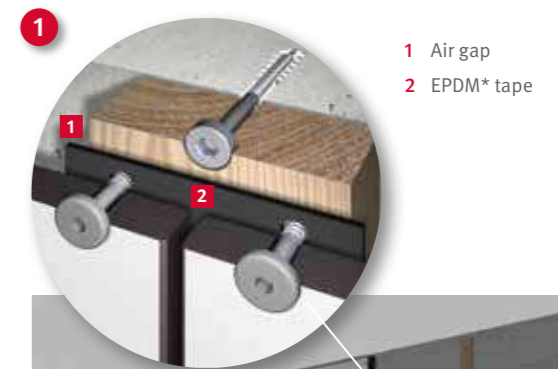

Invisible mechanical mount

The invisible mount of compact laminate by hanging permits straightforward disassembly and looks more visually appealing in comparison to visible mounting methods. Removing the boards is quick and simple. Cables and pipework installed behind the elements are easy to reach. Another advantage is that the elements can be adjusted later on, depending on the chosen mounting system. Tension-free mounting of the elements is also possible.

For all mounting methods that involve hanging, sufficient space must be allowed to raise and lower the elements. This air gap or “hanging space” remains visible as a shadow gap.

Recommendation of systems for invisible mechanical mount:

- Duplex GmbH
- Brem Systeme GmbH
- GHK DOMO GmbH



For hanging using profile strips, the horizontal substructure is grooved to accommodate the rebate rail attached to the wall element. For ease of fitting, the tongue of the rebated rail should be thinner than the groove. The rebated rails on the compact laminate elements should not extend across the full width of the elements, they should be intermittent in order to permit vertical air circulation. Rebate rails made of plywood or metal Z-profiles can be used without issues. If a secure screw joint cannot be achieved with thin compact laminate elements, additional gluing is also possible.

Metal hardware is also offered for mounting wall elements (see Fig. 2).

The chosen system must be used according to the recommendations of the manufacturer to ensure a secure mount.

ATTENTION:

- The installation of compact laminates must always be free of constraints
- It is imperative that compact laminates are able to create a balance moisture on the front and back

Invisible glued mounting

Compact laminate can also be mounted by gluing it to a force-fit substructure using permanently elastic adhesive systems developed especially for the purpose. When using wood as a substructure, it is necessary to apply a primer as a preliminary step to ensure secure adhesion and moisture decoupling.

The systems consist of the adhesive, a mounting tape and the corresponding products for priming the surfaces prior to gluing. The mounting tape is intended for the first fixation. The permanent mount is done with the adhesive. Setting the defined distance is another function of the mounting tape (see Fig. 6). This ensures the required adhesive thickness is achieved to elastically absorb any movements of the board. Observe the processing instructions of the adhesive manufacturer.

»» To adhesive recommendations

6.1.3 Mounting details

Irrespective of the selected substructure and the mounting system, the following detailed designs are usual in practice and ensure the continued and unproblematic mounting of wall cladding.

Butt and joint formation

There are numerous possibilities for making joints or butt joints (see Fig. 3 to 5). However, it is important to ensure that the elements have sufficient clearance for expansion. A minimum board thickness of 10 mm must be taken into account for the versions in the figures 3 and 5.



Top closure

The top closure of the wall cladding must be at a distance from the ceiling to ensure functional rear ventilation and is used for internal ventilation. The distance between the ceiling and the compact laminate also provides the necessary dilation gap (see Fig. 6).

To ensure the full functionality of the rear ventilation, the distance to the ceiling must correspond at least to the size of the rear ventilation gap.



Bottom closure

The bottom closure of wall cladding with compact laminate can be achieved in two ways.

The closure with a gap to the floor works in the same way as the closure of the compact laminate. The distance between the compact laminate and the floor provides sufficient air circulation behind the compact laminate and prevents moisture from stalling behind the wall cladding. But a minimum distance of 50 mm to the floor must be observed (see Fig. 7). Installed bases should be as thin as possible, so that a sufficiently large ventilation cross-section remains available.

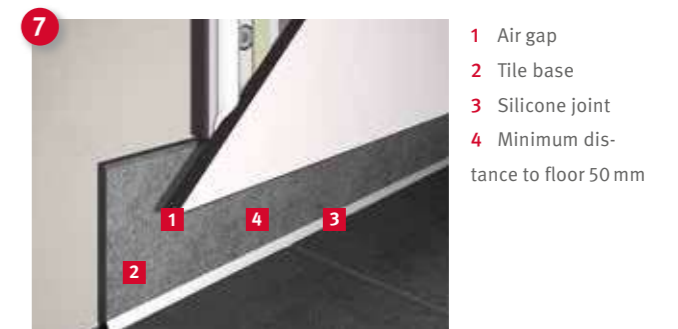

A flush floor installation, used primarily for compact laminate in shower areas, requires the compact laminate to not be directly on the floor, as the board will expand and shrink. A pre-compressed sealing tape (compression tape) maintains the necessary distance during mounting, ensuring the subsequent dilation gap of the board. (see Fig. 8)

The gap between the compact laminate and the floor can subsequently be sealed with a silicone joint in order to prevent moisture from entering. To improve the silicone adhesion, the



edge of the compact laminate should be bevelled. To achieve air circulation in the case of a bottom closure, the rear ventilation gap to the ceiling must be as large as possible. (see Fig. 6, page 31)

Corner solution

When using the compact laminate as a corner solution in humid conditions, the distance between the compact laminate and the wall must be at least equal to the thickness of the substructure. The corner connection between the two compact laminates must be sufficiently large so that size changes due to climate modifications can be balanced out. If the corner connection needs to be sealed, for example when used in shower spaces, this is again done with the help of compression tape, in order to provide the dilation gap. The

gap between the individual compact laminates is protected from incoming moisture with an additional sealing silicon joint (see Fig. 9). Here, too, it is advisable to finish the edge with a bevel.

Surface butt

A usual crash protection solution for wall cladding in hospitals involves the use of compact laminate as half-height wall cladding. A flush transition from the compact laminate to the drywall (see Fig. 10) or an upper mount (see Fig. 10a) are possible. To ensure functional acclimatisation of the compact laminate, a stainless steel bracket can be used as a visual closure.

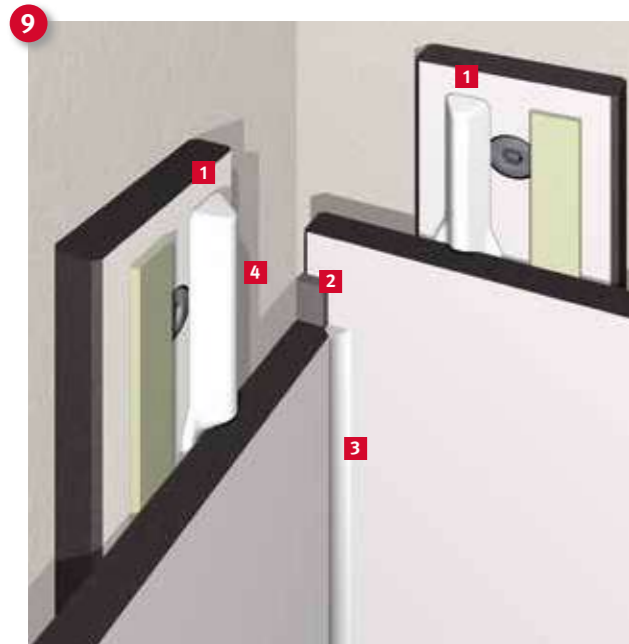

- 1 Compact Laminate strip
- 2 Compression tape
- 3 Silicone joint
- 4 Distance to wall



- 1 Wallpapered gypsum fibreboard
- 2 Stainless steel bracket

Direct mount

For partial wall cladding, compact laminate boards are usually fixed directly to the wall by means of visible screw joints. As there is no rear ventilation, damp proofing must be installed between the compact laminate and the wall. A maximum height of the compact laminate of 300 mm must be observed. The damp proofing will be applied on the wall side. (see Fig. 11)

Possible damp proofing

Liquid coatings

- OTTO CHEMIE: OTTOFLEX liquid foil
- FERMACELL: Fermacell liquid foil
- KNAUF: Knauf surface sealant

Sealing membranes

- OTTO CHEMIE: OTTOFLEX sealing membrane
- KNAUF: Knauf sealing and decoupling membrane

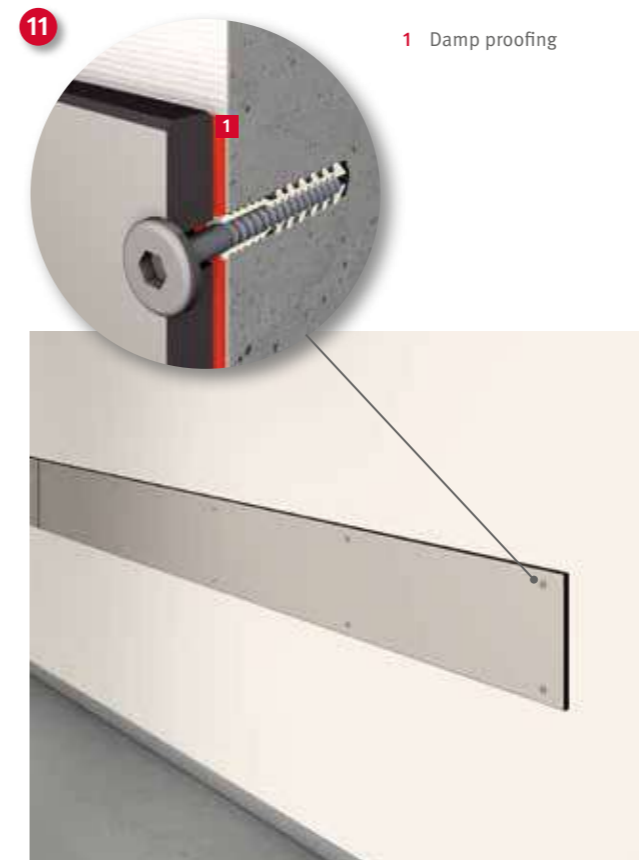

6.2 Shower splashback and sanitary partition

When compact laminate is used in sanitary facilities, it is important to ensure during design and installation that the compact laminate is not subject to standing water and that there is sufficient ventilation of the room. It is imperative to use only corrosion-free construction materials and mounting devices. Application in areas with high humidity requires the mechanical reinforcement of corner connections, for example using dowels or clips, and the use of an adhesive system that is water-resistant after setting. For commercial applications subjected to increased wear and tear, a minimum distance of 120 mm must be maintained between the floor and lower edge of the board. (see Fig. 12)

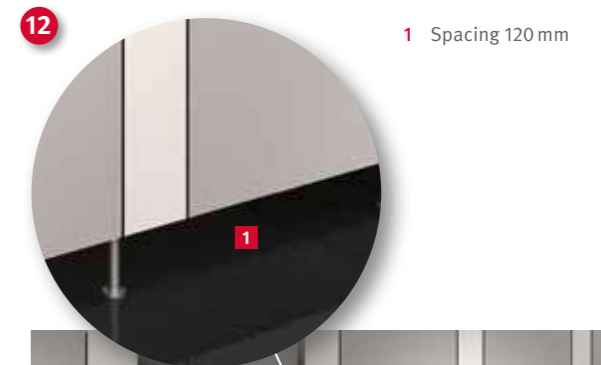

Providing adequate ventilation in the rooms and ensuring that the compact laminate can dry after the shower stall is used is important.

Absorbent mineral substructures such as walls and/or plaster have to be primed with a waterproof elastic barrier. This barrier is generally brushed on and prevents water from penetrating the substructure.

This leaflet describes sealing compounds processed in the liquid state with tiles and boards for interior and exterior applications, taking into account defined moisture exposure classes and substructures. Corresponding sealing systems are available on the left in the section **» Possible damp proofing**.

The moisture exposure classes of the materials have to be coordinated with the manufacturers. Compliance with the processing instructions of the relevant manufacturers is mandatory.

PLEASE NOTE

- Sealing the substrate for shower cladding
- Always use elements for cubicle doors as longitudinal cuts
- Compact laminates may not be exposed to trapped moisture
- It is imperative that compact laminates are able to create a balance moisture on the front and back



6.3 Tabletops

Compact laminate is very well-suited for tabletop applications, for example in offices, conference rooms, schools, and workshops. The board thickness, mounting distances and projection over the base frame have to be laid out depending on the expected loads. Tabletops must have a minimum thickness of 10 mm so that sufficient material is available for secure screw joints (see Fig. 14). Fastening to the substructure can occur in several ways. It is important to guarantee a tension-free assembly. Screws can be driven into the board or a screw-in sleeve may be used. The mounting points in the substructure must be implemented with sufficient dilation gap. The diameter of the drill hole should be 2 to 3 mm larger than the diameter of the mounting device (see Fig. 13).

Board thickness [mm]	Projection [mm]	Mounting distance [mm]
10	max. 100	max. 310
12	max. 150	max. 390
13	max. 200	max. 440

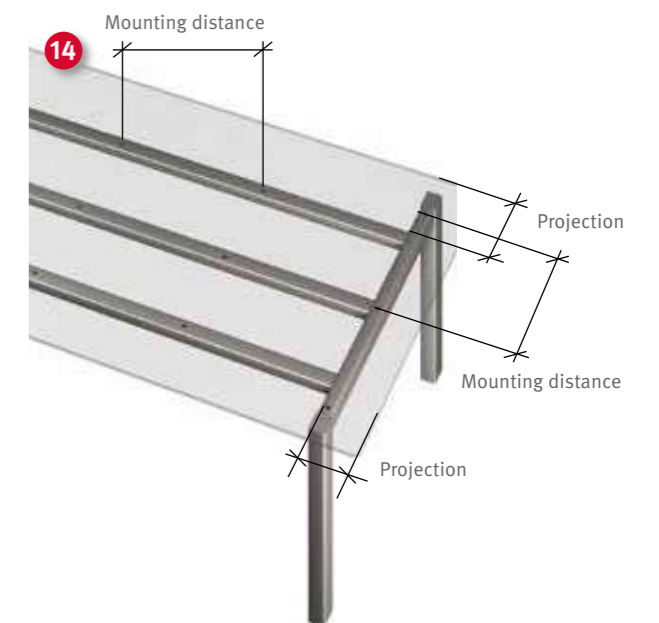

- 1 Crossbar
- 2 Mounting device



6.4 Compact Laminate Worktops

Compact laminates are very often used as compact laminate worktops in kitchens or for washbasins thanks to their slim design, moisture resistance and robustness.

When processing and constructing compact laminate worktops, however, format changes must be taken into account from the outset. Changes in ambient conditions cause the worktop to shrink or expand. In the case of compact laminate worktops, the change in format is about half as large in the longitudinal direction as it is in the transverse direction. As a rule, a dilation gap of 2 mm/m should be provided.

Additional information is available [» in section 7 Processing instructions](#)

6.4.1 Installation of hobs and sinks

Cut-outs for hobs or sinks must be produced according to the measurements and positioning details and/or using mounting templates supplied by the manufacturer. Enclosed or integrated dry seals of the manufacturer are to be used according to the mounting instructions – see Fig. 15.

When making cut-outs in the compact laminate worktop, the information in section [» 7.2.3 Cut-outs](#) must be observed in order to avoid cracking.

The cut-out edges must be carefully protected against moisture penetrating into the body. It is true that the compact laminate worktop has a homogeneous and moisture-resistant board structure, which makes joint sealing not absolutely necessary. However, the latter prevents moisture from penetrating the body. Ensure correct centring and an adequate safety margin to the cut edge, particularly for hobs. Follow the manufacturer's instructions. For safety reasons the hob should not rest against the cut edge since under certain operating conditions, temperatures could rise to 150 °C. (see Fig. 15).



Classic

When installing and mounting conventional sinks or hobs, a special solution is required for the compact laminate worktop due to its slim design. Mounting strips are recommended for this purpose to ensure easy assembly (see Fig. 16). The strips must be glued before the sink is installed (see Fig. 17.)

A stress-equalising adhesive system should be used for glueing the strips.

[» To adhesive recommendations](#)

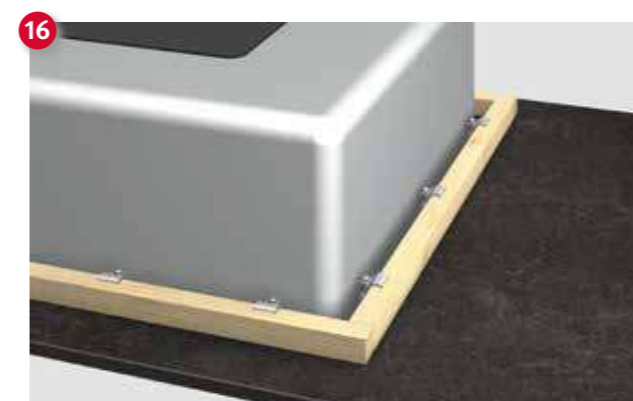

Flush

Another installation option is the flush mounting of a sink or hob (see Fig. 18). In this case, make sure that at least 6 mm of the compact laminate worktop thickness remains (see Fig. 18).

In the case of deeper cut-outs, for example if the hob design requires it, appropriate substructures must be considered to provide additional support for the worktop.

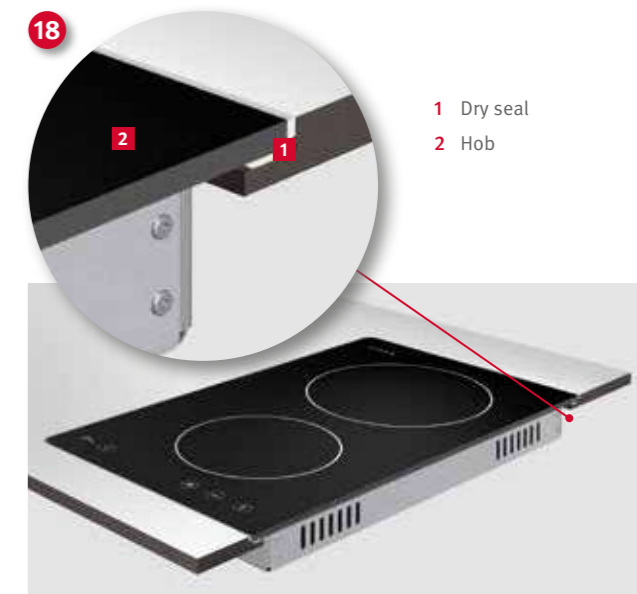

Undermount

The water-resistant compact laminate worktop makes it possible to fit an elegant and modern undermount sink (see Fig. 19). It is also important here that the corner cut-outs for the sink are made with a minimum radius of 5 mm, [» see section 7.2.3 Cut-outs](#). The individual mounting steps may vary depending on the sink manufacturer. The manufacturer's instructions must be followed.

In addition to gluing the sink under the compact laminate worktop, which also serves as a seal, most sink manufacturers supply additional fastening brackets to support the bonding.



Positioning and installation gaps

The remaining worktop rack should not be less than 50 mm wide at any one place. For ergonomic reasons, the distance between the hob area and an upright cupboard should not be less than 300 mm. Allow for the hob manufacturer's specified safety margin. The same distance applies for the gap between the sink and the hob – see Fig. 20.

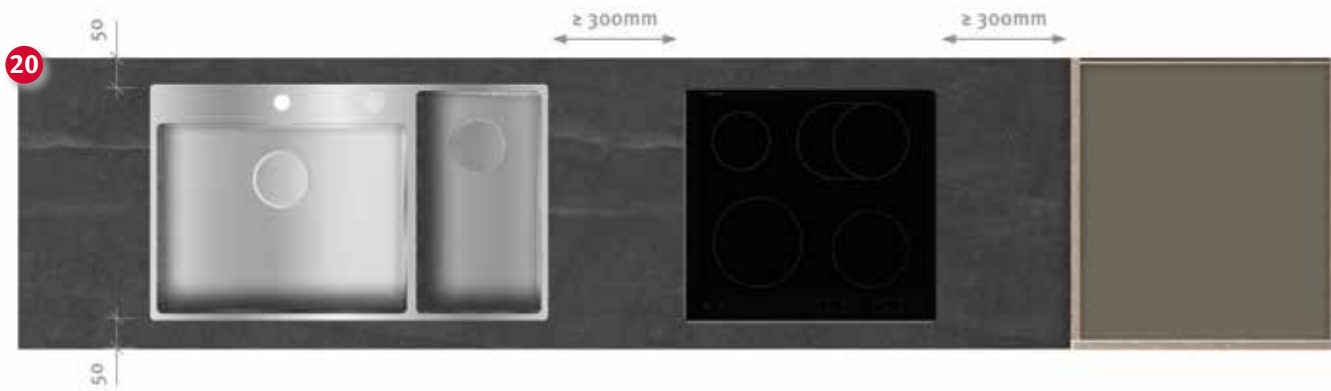

In the area of corner joints, a minimum distance of 300 mm must also be taken into account when planning cut-outs or recesses – see Fig. 21.

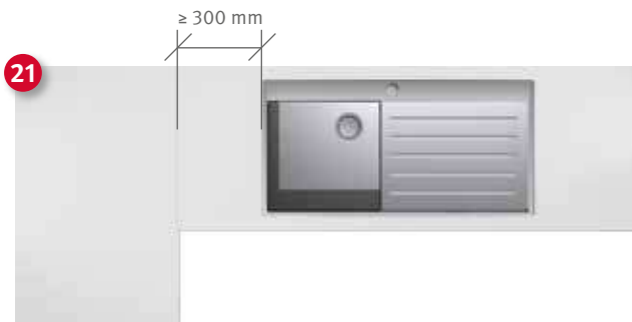

Once the worktop has been cut, any further transportation must be carried out with utmost caution to prevent the board from snapping. Compact laminate worktops must be carried upright because cut-outs can be damaged more easily if the boards are carried horizontally.

For conventional base units, a standard construction can generally be used. When constructing sink and/or cooker base units, the installation of metal crossbars is recommended – see Fig. 22. The compact laminate worktop is secured against possible bending by the metal crossbar, as the worktops are weakened by sink and/or hob cut-outs and the contact surfaces on the base units are minimised.

In addition to stabilising, the metal crossbars also serve to fix the worktop or panels – see Fig. 23.



For safety and ergonomic reasons, the planning of a kitchen should be discussed with a kitchen specialist and the installation should be carried out by a specialist company. Particularly electricity, gas and water supply connections must be carried out by trained specialists.

6.4.2 Worktop and corner joints

In general, a worktop length of 4,100 mm allows jointless spanning so that board joints are avoided. On the other hand, worktop corner joints occur frequently. These should not be weakened by notches or cut-outs such as for hobs or sinks. Corner joints on worktops are made by mitring on the circular saw or milling using CNC milling bits or hand-held milling bits with the aid of templates – see Fig. 24 and 25.



Worktop joints and corner joints must be made to fit precisely and tightly. With compact laminate worktops, sealing is not necessary due to the homogeneous worktop structure. Sealing of butt joints and corner joints, however, also prevents moisture from penetrating into the body. For this purpose, the EGGER sealant was specially developed for sealing the butt joints (corner joints) of kitchen worktops. The flexible sealant reliably prevents the penetration of moisture and liquids into the butt joint. It is resistant to cleaning agents, water, grease, oil, etc., and is available in grey, white, black and brown. The content of the 10 g tube is sufficient for an average butt joint length of 650 mm – see Fig. 26.

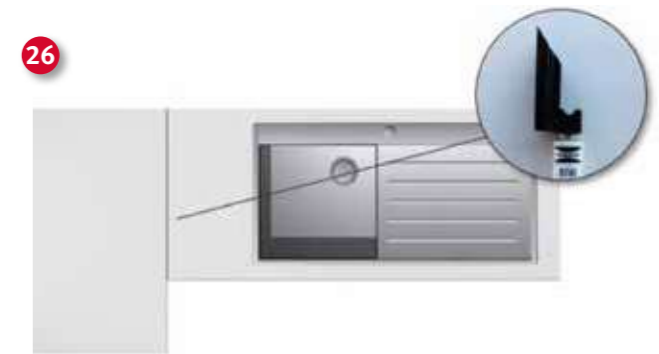

The worktop already has bevel milling on the long edges. If the transverse sides are also bevelled, the contour milling that is usual for corner joints can be dispensed with. The bevel separates the two worktops from each other, i.e. the bevel on the front of the worktop is deliberately accentuated, as is also the case with stone worktops – see Fig. 54. If the compact laminate worktop is to be cut to length, it is recommended to apply a bevel of identical design.

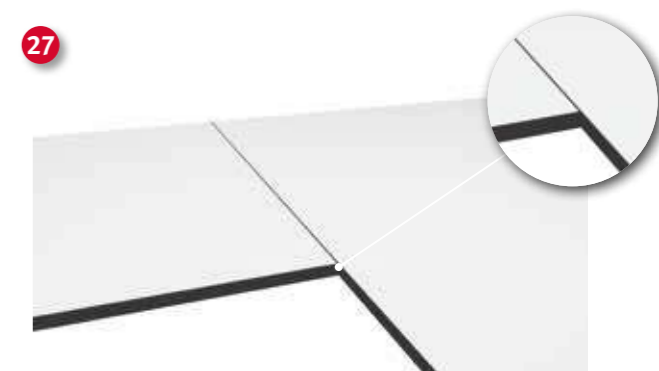

The application of the sealant begins with piercing the membrane cap of the tube and then screwing on the black application aid – see Fig. 27. The application aid is then guided along the top of the worktop butt joint and the sealing compound is pressed evenly out of the tube. Immediately after applying the sealant, the worktops must be joined and screwed together. Any residue that may have escaped should be removed immediately with a suitable cleaning agent.

For more detailed information and combination recommendations of the colours for the respective worktop decors, please refer to the technical data sheet

EGGER sealing for corner joints

The individual worktops are fastened with the aid of mechanical fastening systems (worktop connectors) and are held in place by the use of fastening aids, so-called spring guides / plastic lamellas, as well as additional gluing. The fixing aids must always be positioned in the centre of the board thickness. The compact laminate worktop requires the use of special worktop connectors due to its low material thickness. EGGER offers corresponding connectors as a set suitable for 12 mm thick worktops – see Fig. 28.

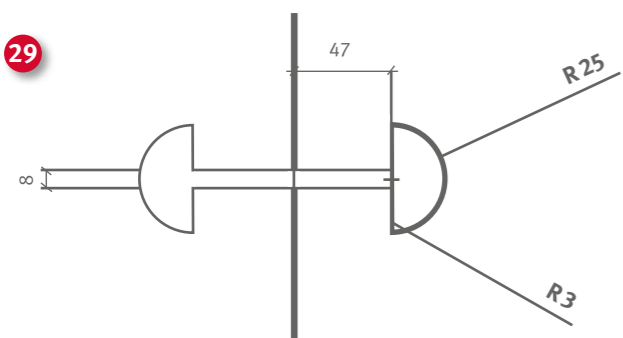

The compact laminate mill pocket for the 12 mm connector is milled 8 mm deep – see Fig. 29.

For further information, please refer to the technical data sheet **EGGER worktop connectors**. The number of worktop connectors is determined by the worktop width. Two connectors each up to ≤ 799 mm width and three connectors ≥ 800 mm worktop width are common. The flushness of the butt joint is achieved by using the worktop surface as the reference edge for milling the grooves for the spring guides and by ensuring that they are firmly seated.

Proceed as follows:

1. Lay the worktops on the base framework and check the joints including spring guides and grooves for correct fit.
2. Adhesive as in section **» Bond and furniture construction**
3. Apply sealing compound (e.g. EGGER sealant) evenly and continuously to the upper milled or cut edge, if necessary with an application aid. You should do this just before screwing the worktop connectors in place.
4. Join worktops, insert fittings and tighten screws slightly. Align worktops horizontally with wedges or levers and vertically using a rubber mallet or screw clamps (use jaw covers). Tighten worktop connectors fingertight after aligning. Take care when tightening that the two worktop surfaces remain aligned and the sealing compound emerges. Do not place any stress on the worktops while the sealant is hardening.
5. Remove excess sealing compound immediately. Clean the worktop surface with a suitable cleaning agent such as citrus cleaner or acetone. Caution: Acetone can affect the surface if left for a long period. We therefore recommend masking off the butt joint area with masking tape.

Assembly video compact laminate worktops

6.4.3 Substructure and mounting

Before sealing the long edge of the worktop against a wall, make sure that it is not just adequately supported but is also joined to the substructure. Stresses can otherwise occur that will interfere with the sealing joint.

Irrespective of the mounting type selected, it is necessary to provide a dilation gap of 2 mm/lm. In order to properly ventilate the compact laminate, it is necessary to design the upper part of the body as a crossbar. Closed body tops are not permitted and can cause the boards to warp after the compact laminate worktop has been installed. The undermount crossbars as substructure ensure the appropriate rear ventilation and equalisation of moisture in the boards. This is not only necessary for the top of the body base unit, but also for side flanks that are designed as compact laminate (see Fig. 30).

The substructure can be made of laminated chipboard or compact laminate strips to ensure that the compact laminate is moisture-equalised (see “Wall cladding” section).



1 Compact Laminate worktop 1,300 mm
2 Substructure

The connection of the side panel to the worktop can be either mitred (see Fig. 30a) or butt against each other (see Fig. 30b). For both versions, the use of fastenings aids (spring guides/ plastic or wooden lamellos) is necessary.

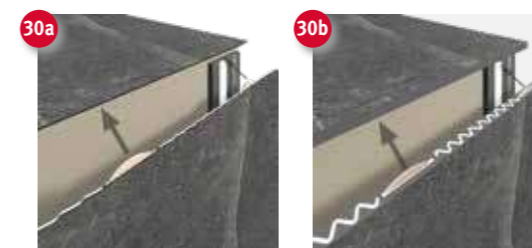

These should be paste with adhesive as shown and adhesive should also be applied to the narrow surface of the connection.

To connect the boards to the body, they can be screwed **» see section 7.2.5** or glued **» see section 7.2.4**.

Mechanical mount

Mechanical mount is usually carried out by a screw joint through the crossbar. Here, too, the compact laminate worktop must be pre-drilled and the drilling diameter of the crossbar must be larger **» see section 7.2.5** Screw joint. The compact laminate worktop is then screwed to the crossbars using a flat-head screw (see Fig. 31).

- 1 Flat-head screw
- 2 Drill hole larger than screw
- 3 Crossbar

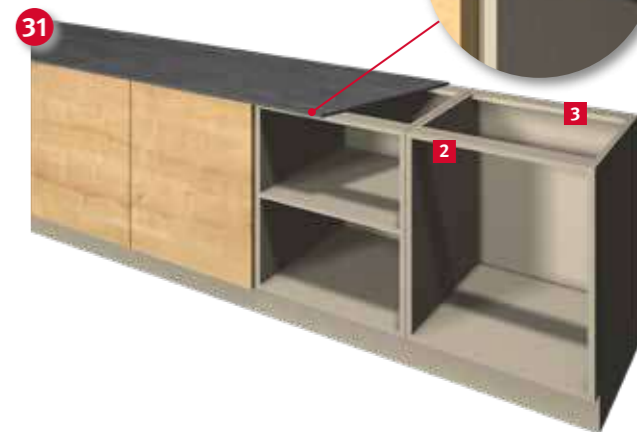

Glued mount

Another way of attaching the compact laminate worktop to kitchen base units is by gluing. When gluing, make sure to use a permanently elastic adhesive system with the required adhesive thickness to be able to elastically absorb any movements of the board. Suitable adhesive systems are usually designed with a double-sided adhesive tape, which specifies the initial adhesion and adhesive joint thickness, as well as the adhesive **» see section 7.2.4 Bonding**. It should be noted that, unlike with mechanical mount, the glued version creates a shadow gap of approx. 3 mm, which must be taken into account in the overall joint pattern of the furniture (see Fig. 32).

- 1 Double-sided adhesive tape
- 2 Adhesive
- 3 Visible shadow gap
- 4 Crossbar

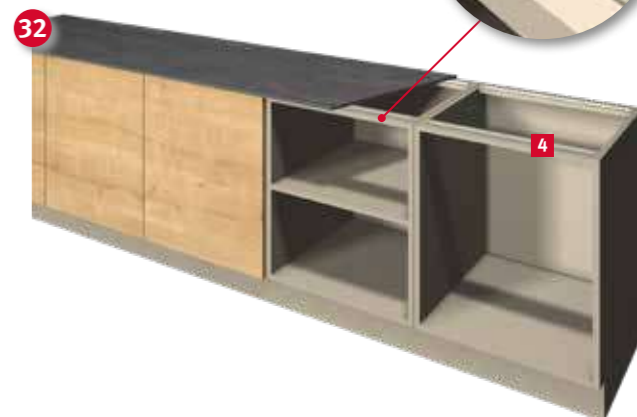

6.4.4 Wall closure

Before sealing the long edge of the worktop against a wall, make sure that it is not just adequately supported but is also joined to the substructure. Stresses can otherwise occur that will interfere with the sealing joint.

Irrespective of the mounting type selected, it is necessary to provide a dilation gap of 2 mm/lm. In order to properly ventilate the compact laminate, it is necessary to design the upper part of the body as a crossbar.

When mounting, make sure that the worktop is not tilted towards the wall. This will result in water collecting at the joint area. Clean and degrease around the sealing joint on both the worktop as well as the wall joint and pre-treat with a bonding agent depending on the sealing compound used (see Fig. 33).

It is advisable to use a laminate bonded board as splashback. Detailed information on processing and installation can be found here in the [Processing instructions splashbacks](#).



6.5 Furniture doors

Doors should not be wider than they are high. Since format changes are only half as large in the longitudinal direction compared to the transverse direction, cutting door leaves in the longitudinal direction of the compact laminate is recommended. Excessive differences in temperature or relative humidity between the front and reverse sides of the door can cause the compact laminate to warp. This is why sufficient air circulation must be ensured, for example when installing toilet cubicles or changing rooms. The door width, height and weight are deciding factors for the number of hinges required. Other factors, such as the installation location or whether additional stress is to be expected from the attachment of coat hooks, for example, can vary greatly from case to case and must be taken into account.

Performing a trial mounting is recommended. For heavy duty applications, an additional hinge can be fitted at max. 100 mm below the upper hinge. The upper and lower hinges should be located at a minimum distance of 100 mm max., measured from the outer edge. The manufacturer's processing instructions and installation recommendations must be observed.

Possible hardware manufacturers

- Prämeta Serie 3000
- Blum Expando T
- Hettich Sensys thin door hinge
- Häfele special hinge, for laminate doors (HPL)

7. Processing instructions

7.1 Use of Compact Laminates

7.1.1 Storage

Compact laminates must be stored in a closed and dry room at approximately 18 °C to 25 °C and a relative humidity of approximately 50% to 65%. Once the original packaging is removed, the compact laminate must be stored on full-surface, horizontal, straight, stable protective boards. Direct floor contact and/or exposure to sunlight must be avoided at all times. A laminated protective board (not rawboard) of at least the same format must be used to cover the top and bottom board (see Fig. 34).

If horizontal storage is not possible, the compact laminate must be stored at an angle of approximately 80° against a full-surface support with counter-bearing. Using a laminated protective board of at least the same format is required for upright storage as well (see Fig. 35 and 36).

- 1 Compact Laminate stack
- 2 Laminated protective board



Horizontal storage of compact laminates

7.1.2 Conditioning

Compact laminate reacts to changes in ambient conditions with dimensional movement. For this reason, storage and processing conditions should correspond as closely as possible to the climate at the subsequent place of use. Prior to installation, compact laminate elements should be conditioned for an adequate period of time at the installation location under the conditions of subsequent use. Compliance with the storage recommendations is required on construction sites as well.

- 1 Compact Laminate stack
- 2 Counter-bearing with support at 80°
- 3 Laminated protective board



Correct storage of Compact Laminates

Incorrect storage of Compact Laminates

7.1.3 Handling

After removing the packaging and prior to processing, the compact laminates should be inspected for visible damage. Special care must be taken when transporting and processing compact laminates due to their heavy weight. As a rule, anyone transporting and handling compact laminates should wear personal protective equipment such as gloves, safety shoes and suitable work wear. The boards must be lifted. The decor sides should never be pushed against one another or dragged over one another (see Fig. 37).

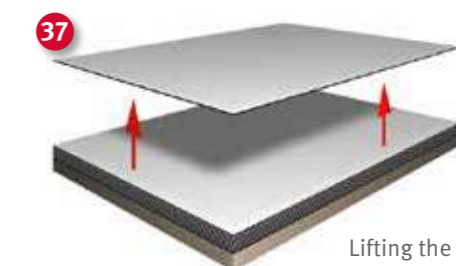

Lifting the Compact Laminate

7.2 Processing

Due to the high density and the high cutting forces that arise, the processing of compact laminates leads to shorter tool life compared to other wood-based materials. Sharp blades should be used to ensure optimal shredding and to avoid odour generation. Hard metal tools are mainly used. Diamond-tipped tools are recommended for processing large quantities and automated processing centres. Ensure that the tool blades are maintained in good condition to obtain satisfactory results. To ensure economical fabrication, especially prior to processing a large production batch or implementing challenging projects, it is advisable to consult manufacturers on the most appropriate tool selection.

Notwithstanding the good dimensional stability of compact laminate, changes in the ambient conditions can result in format changes.

The orientation of the fibres in the core layers gives the compact laminate a production or running direction (see Fig. 38).

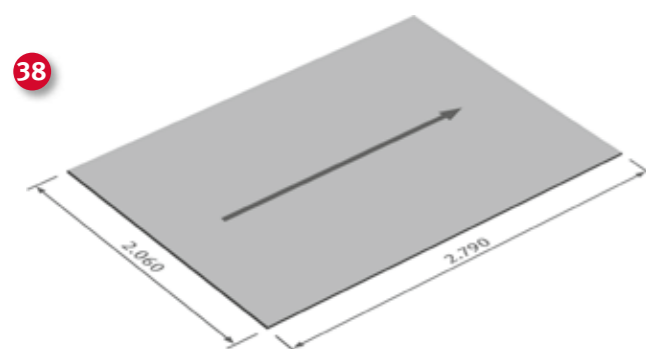

The arrow indicates the running direction/longitudinal direction of the board.

Format changes are approximately half as large in the longitudinal direction as in the crosswise direction. Format changes have to be taken into account from the outset in design and processing. As a rule, a dilation gap of 2.0 mm/m should be provided. Different ambient conditions in front of and behind the compact laminate elements can lead to warpage. It is therefore essential that compact laminate wall cladding always makes provision for adequate rear ventilation, which allows temperature and humidity to equalise, as well as acclimatisation.

The production direction of double-sided decorative compact laminates can often only be identified from the production dimensions. Woodgrain and directionally printed decors constitute an exception. When working with cut-to-size boards, it is important to ensure that the production direction is always matched up during installation. In view of the risk of confusion with cut-to-size boards, the running direction should be marked on board leftovers.

ATTENTION:

- Take into account a dilation gap of 2.0 mm/m – the installation of compact laminates must always be carried out without constraints
- Execution with sufficient rear ventilation – compact laminates must be able to create a balance moisture on the front and back
- When installing cut-to-size parts, ensure the same direction of production

7.2.1 Cutting and milling

The use of board saws or sliding table saws is recommended for cutting compact laminates to size. To obtain a good cutting result, the relationship between number of teeth (Z), cutting speed (vc), and the feed rate (vf) should be taken into account. For finishing on the construction site, plunge saws and a suitable guide rail can be used.

Depending on saw blade projection, the entry and exit angle change, and thus also the quality of the cut edge. If the upper cut edge becomes unclean, the saw blade must be set higher. The saw blade must be set lower in case of an unclean cut on the bottom. The best height setting must be identified.

Diamond-tipped tools are recommended for processing compact laminate. The suitability of carbide-tipped tools is limited. Tools with segmented blades should not be used as far as possible, as the overcut in the overlap zone usually remains visible. Because of the high cutting pressure, secure workpiece and tool control is of particular importance. Numerous edge profiling options are available. Remaining signs of milling can be removed by sanding. Sharp corners and edges should be rounded to eliminate the risk of injury. An even edge colour can be achieved by applying a silicone-free oil. The oil provides additional protection against contamination and unwanted oxidation effects and thus ensures a permanently flawless appearance.

The following are suitable for the treatment of compact laminates with silicone-free oils:

Liquid coatings

- ADLER LEGNO-ÖL 50880FF
- ADLER LEINÖLFIRNIS 95901
- HESSE PROTERRA NATURAL-SOLID-OIL GE 11254
- Rubio Oil Plus Pure (colourless)

ATTENTION:

- Visible side (decor side) up
- Pay attention to the correct saw blade projection
- Adjust number of revolutions and number of teeth to feed speed
- The use of a scoring circular blade is recommended to obtain clean cuts on the bottom of the board

7.2.2 Drilling

Drill bits designed for plastic are best suited for drilling compact laminates. Please observe the specifications of the tool manufacturer. Twist drill bits for drilling metal or wood can also be used, however, the rotational speed and feed rate must be reduced.

For through holes, the compact laminate should be resting on a solid base which can be drilled into. Good removal of the drilling chips must be ensured. Before the drill bit breaks through, the feed rate should be reduced in order to avoid break-outs on the exit side. For drill holes that do not go through, so-called blind holes, the minimum board thickness that must be kept is 2 mm. For drill holes parallel to the board surface, the minimum board thickness that must remain on either side of the drill hole is 3 mm (see Fig. 39). Cutting, milling and drilling tools should always be selected in coordination with the tool manufacturer.



» For further information, please refer to the processing and tool recommendations of compact laminates in the download area at to.egger.link/compactlaminates-black-core

7.2.3 Cut-outs

Cut-outs and recesses, for example for switches, ventilator grilles or accesses, must always be rounded off, as sharp-edged corners can lead to cracking (see Fig. 40 and 41). Inside corners should be cut with an inner radius of at least 5 mm. All edges must be smooth and free of cracks and notches. Grooves and rebates also have to be bevelled to avoid notch cracks. Cut-outs can be made directly with a router or pre-drilled with an appropriate radius and then sawn out from drill hole to drill hole. Sufficient expansion gaps must be allowed for integrated components.



40 1 Minimum radius 5 mm

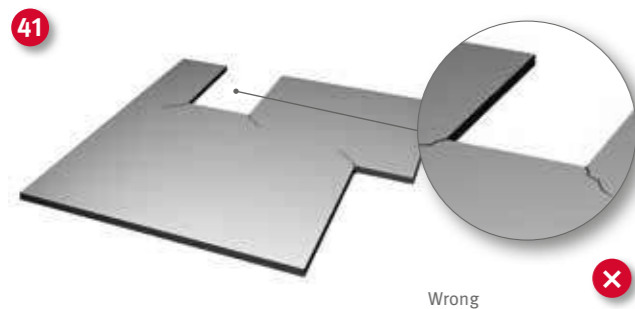
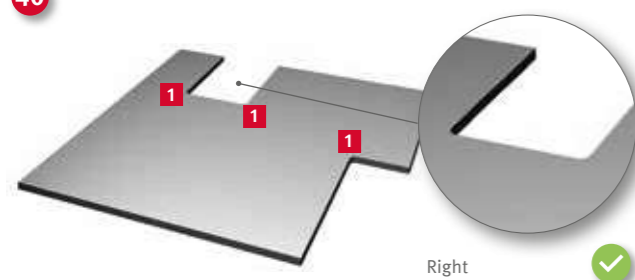

Bonding of corner joints

Higher strength joints between compact laminate elements are achieved with the combination of gluing and mounting devices, spring guides (e.g. made of compact laminate) or grooves. Note that compact laminate elements may only be joined to each other in the same production direction. Fig. 42 to 47 below illustrate some possibilities for creating sturdy compact laminate joints.



7.2.4 Bonding

When bonding together two compact laminates, it is important to ensure that dimensional movements are not obstructed. To avoid stress, only adequately conditioned compact laminates should be bonded together and always only in the same running direction. Prior to bonding, the boards have to be free of dust, grease and dirt, and pre-treated as necessary. Own attempts are recommended. Please observe the processing guidelines of the adhesive manufacturer.

Depending on the type of application, the following instructions must be observed during bonding:

Bond and furniture construction

Visually thicker boards can be produced by doubling or upstands. When doubling, corresponding compact laminate strips are glued on in the edge area (see Fig. 48).

Bonding of butt joints, as is the case when joining two compact laminate worktops, for example, is used as additional support to spring guides/plastic lamellas. For more information, see section 6.4.2 Worktop joints and corner joints. The same running direction of the compact laminate parts must be ensured here. The following adhesives are suitable for bonding:

→ OTTO CHEMIE
Ottocoll M500
Ottocoll M560

→ JOWAT
Jowat 690.00

→ INNOTEC
Adheseal Project
Powerbond XS 330

→ SIKA
SikaTack Panel

Upstand / mitre joint

For thicknesses up to 100 mm or if the decor has to be visible on the edge for aesthetic reasons, an upstand (see Fig. 49) is a possible solution. First, the two components to be connected together are mitred at 45°. Then the work piece is placed on a level surface, face side down, so that the tips of the mitres are touching. Adhesive tape is then applied to this butt joint.

It is also important to ensure that the parts run in the same direction. Then both work pieces have to be turned over with corresponding caution. Then the adhesive is applied (see Fig. 50) and then the shorter work piece or upstand is flipped up (see Fig. 51). Until the adhesive has set, the upstand or the mitre joint has to be secured in the correct position with adhesive tape.

Adhesive recommendations

→ OTTO CHEMIE
Ottocoll P85
Ottocoll P86

→ INNOTEC
Repaplast Repair
Timber Fix 30

→ WÜRTH
PUR Rapid



Bonding wall cladding

Bonding compact laminates in the area of wall cladding must be carried out with a permanently elastic adhesive system specially developed for this purpose. The compact laminate can be bonded to solid wood, multiplex or metallic substructure materials. The specified adhesive thickness must be ensured in order to be able to elastically absorb any movements of the board. To invisibly glue compact laminate onto the substructure, we recommend the

adhesive manufacturers/adhesives below:

→ **INNOTEK**
Adheseal Project
Powerbond XS 330

→ **JOWAT**
Jowat 690.00

→ **SIKA**
SikaTack Panel

Surface bonding

Surface bonding of large dimensions is only possible in exceptional cases. Joints that are subject to major stress, for example due to vibrations, impact or similar, should be reinforced with mechanical connecting elements.

Due to the material's inability to absorb moisture or occurring gases, full-surface bonding of compact laminates with laminate is not recommended.

7.2.5 Screw joint

Cutting screw threads in compact laminate is straightforward. Self-tapping screws can also be used without a problem. Screws with a slow thread are recommended as they achieve a better pull-out resistance. Pre-drilling is essential in all cases. For high additional loads, it is recommended to use a screw-in socket, e.g. RAMPA type ES or RAMPA type E for thin compact laminates from 6 mm. This also enables a higher degree of prefabrication and easier disassembly. A minimum of 25 mm must be observed for screw joints parallel to the board level and the bore hole diameter must be selected so that the board does not crack.

Surface screw joints with trough holes must have sufficient clearance to compensate for the dimensional movement resulting from temperature and humidity fluctuations. The diameter of the drill hole should be 2 to 3 mm larger than the diameter of the fastener. In this way, tension due to the dilation and shrinking movement resulting from changing climate conditions can be avoided. The use of countersunk screws (see Fig. 53) is not recommended, as these prevent the expansion of the board. Instead, flat-head screws should be used (see Fig. 52). These are available from various manufacturers (e.g. MBE) and also come with head varnish.



ATTENTION:

- Make the diameter of the hole 2 to 3 mm larger than the diameter of the screw shank
- Avoid using countersunk screws
- Formation of sliding and fixed points

The design of fixed and sliding points is valid for vertical and horizontal designs regardless of the application, see next page.

Fixed points

The fixed point serves to evenly distribute the dilation gap and should be positioned as centrally as possible. The drill hole diameter is the same as the diameter of the mounting device (see Fig. 54).

In the figures, an EPDM* sealing tape has been applied to the wooden substructure to protect against moisture.



Sliding points

The drill hole diameter of the sliding points should be 2-3 mm larger than the mounting device (see Fig. 55). The drill hole should be covered by the head of the screw. Washers should be used when necessary.

The required dilation gap is established based on the largest distance of the fixed point to the board edge. The sliding point drill hole diameter must be increased by 2 mm for every metre of length. In all cases, the screw must be positioned exactly in the centre of the drill hole. If necessary, this can be ensured by using suitable drilling jigs. For interior applications, the mounting distances listed in the table can be used. (see Fig. 56).

Recommendation of EPDM tapes

- MBE EPDM JOINT TAPE
- INNOTEK EPDM JOINT TAPE

* EPDM stands for ethylene propylene diene monomer. This is a synthetic rubber. EPDM is very resistant to UV, ozone and other atmospheric influences.



Board thickness [mm]	Maximum fastener distance	
	a [mm]	b [mm]
8	790	500
10	920	670
12	960	900
13	970	920

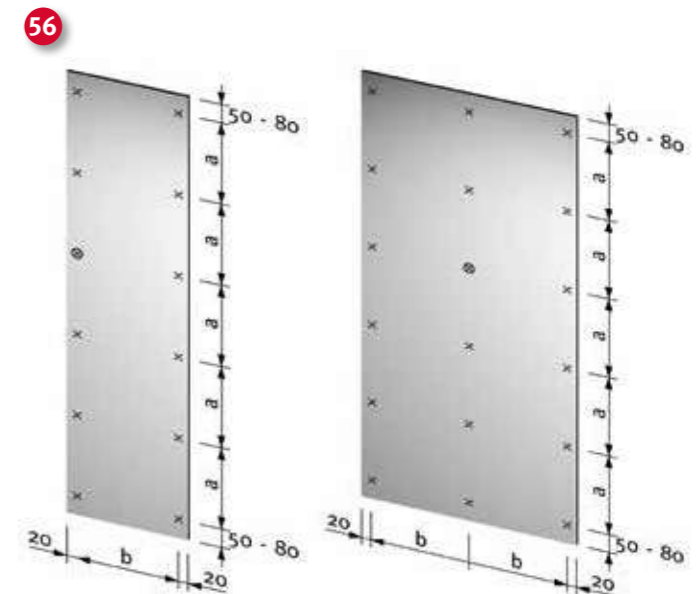

⊗ = fixed point, × = sliding point



7.3 Cleaning and usage recommendation

Due to the hygienic and dense surface, compact laminate does not require any particular care. As a general rule, stains and spilled substances such as tea, coffee and wine, etc., should be cleaned up immediately, as the cleaning effort increases if they are left to dry. When cleaning is necessary, mild agents should be used. Cleaning agents must in particular not contain any abrasive components, as they may adversely affect the gloss level or scratch the surface.

The following information should be observed for daily use:

- Compact laminate surfaces should not be used as a cutting surface, as this can also leave cutting marks on compact laminate surfaces. Always use a chopping board.
- Putting hot items such as pots and pans on the compact laminate surface directly from the hob or straight out of the oven must be avoided, since the gloss level may change or surface damage may occur depending on the heat level. Always use heat protection.

→ Spilled liquids should always be wiped or cleaned up immediately since extended exposure to certain substances can change the gloss level of compact laminate surfaces. Especially in the areas around cut-outs and joints, spilled liquids should always be cleaned up quickly and thoroughly.

→ These recommendations apply in particular to matt compact laminate surfaces as they are more prone to showing signs of use. For detailed information please see the data sheet

Cleaning and care recommendations for EGGER product surfaces

7.4 Health and environment

Please always use personal protective equipment (PPE) when using and processing compact laminates. The following information on health and environment relates to the processing of compact laminates.

Emissions

Processing and use outside the technical properties and standard classification of the compact laminates can increase emissions and thus lead to health hazards. Please observe the marked emission class for the product.

Resins

For the manufacturing of compact laminates, we only use polymerised resins which, as such, do not exhibit any hazardous properties after curing in the product and are harmless for the intended use of the product. In particular, free melamine as such is not contained in these compact laminates in a concentration that would trigger additional reporting obligations, for example under Regulation (EC) No. 1907/2006 (REACH). Furthermore, compact laminates comply with the existing migration thresholds according to Regulation (EU) No. 10/2011 on plastic materials and articles intended to come into contact with food.

Health hazard due to dust generation

Dust may be generated during processing. There is a risk of sensitising the skin and respiratory tract. Depending on the processing and the particle size, especially in the case of inhalation of dust, there may be further health hazards. The generation of dust must be taken into account when assessing the risks at the workplace. Particularly in the case of machining processes (e.g. sawing, planing, milling), effective extraction must be used in accordance with the applicable occupational health and safety regulations. Suitable breathing protection has to be worn if no adequate extraction system is in place.

Fire and explosion hazard

Dust generated during machining and processing can lead to fire and explosion hazards. Applicable safety and fire protection regulations must be observed.

Recycling

Further information on health and environment can be found in

Environmental and Health data sheet (EHD) - Compact Laminates Black

Disposal

Due to their very high calorific value, compact laminates are highly suitable for thermal disposal in appropriate combustion plants. Specific national laws and ordinances on disposal have to be observed in general.

These processing instructions were prepared based on the best available information and with due diligence. The information provided is based on practical experience and in-house testing, and reflects our current level of knowledge. It is intended for information only and does not constitute a guarantee in terms of product properties or suitability for specific applications. We accept no liability for any mistakes, errors in standards, or printing errors. Furthermore, the continuous further

development of compact laminate products as well as the amendment of standards and public documents may result in technical changes. Therefore, the content of these processing instructions cannot serve as instructions for use nor as a legally binding agreement. Our General Terms and Conditions of Sale and Delivery apply.



Sample shop

Are you looking for a sample? We have simplified ordering samples for you. From now on, you can order your desired sample directly from the corresponding decor or product detail page.

Order your desired decor samples easily and conveniently online or via our app.

Scan me!



[to.egger.link/
shop-innenausbau](https://to.egger.link/shop-innenausbau)



Time for more: The Decorative Collection 24+

Design and realise extraordinary projects in furniture and interior design. We have the right products for these projects – no matter the requirements: Choose from a diverse product range, further refined with trend-oriented decors and surfaces. All information regarding our available products is available here.

Time for your service experience

Thanks to the digital services of the Decorative Collection 24+ we offer you new opportunities and possibilities. The focus is on the digital link between the Collection folder of the revised website, the Decorative Collection app and the Virtual Design Studio.

Decorative Collection App

Thanks to the app, the entire EGGER decor selection is always at your fingertips, no matter where you are. Be inspired and create individual decor collections and mood boards. With the enhanced scan function, you can access the full view of the decors and detailed information on availability even faster. Order the desired samples for your projects even faster and easier.



Online and offline

You can decide yourself which data should be available to you offline in the app. As such, this service can also be available to you when you are not online.



Improved scan function

See full decor views and more detailed information about availability even quicker.

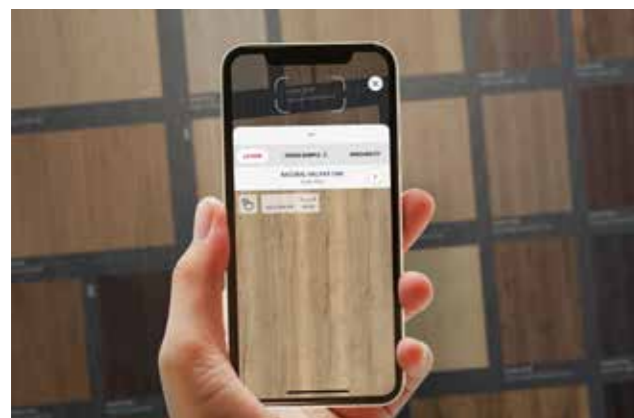

Scan me!



to.egger.link/app

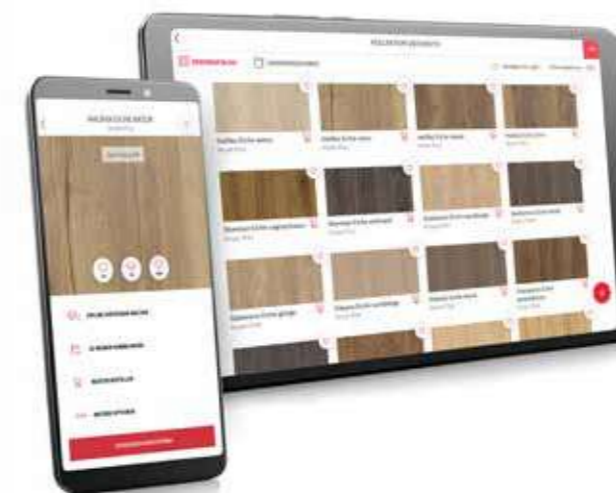

Digital availability guide

Check on our website or via our app for which product types and variants your desired decor is available.

Scan me!



to.egger.link/lieferverzeichnis



Decor visualisation

Implement your ideas digitally in the Virtual Design Studio. Choose from various rooms to stage your desired decors and combinations. True-to-life light and shade ratios and realistic application images convey an authentic sense of space and give you the opportunity to present your ideas digitally.

Scan me!



to.egger.link/vds

MORE FROM WOOD.



Furniturefoljs.en_09 / 2024_ DSR
All our shown and mentioned decors are reproductions. Colour - matching decor selection only possible on the original sample.
Due to variables in the printing process, colours may vary slightly from the actual product. Subject to technical modifications and printing errors.

Dystrybutor

DAEDALUS

PŁYTY, BLATY, CIĘCIE I OKLEJANIE

Daedalus Sp. z o.o.
ul. Magazynowa 50
41-700 Ruda Śląska

Kom: +48 575 886 996
E-mail: biuro@daedalus.com.pl

www.daedalus.com.pl

NIP: 6263018785
REGON: 362094443